

DENTAL X-RAY

LCD

PHOT-X IIS

505

OPERATOR'S INSTRUCTIONS

- Wall Mount Type WK
- Floor Mount Type FK1/FK2
- Mobile Type FM
- Room Mount Type RK
- Ceiling Mount Type CK



⚠ WARNING

This X-ray equipment may be dangerous to patient and operator unless safe exposure factors, operating instructions and maintenance schedules are observed.

 **Belmont[®]**

INDEX

[1] INTRODUCTION.....	1
[2] MAJOR COMPONENTS.....	3
[3] LAYOUT OF CONTROLS.....	5
[4] FUNCTION OF CONTROLS	6
[5] OPERATING PROCEDURES	10
[6] SETTING MODE.....	11
[7] OPTIONAL HAND EXPOSURE SWITCH.....	12
[8] DIGITAL IMAGING SYSTEM	13
[9] INFECTION CONTROL AND CLEANING	13
[10] ERROR CODES	14
[11] MAINTENANCE.....	15
[12] TECHNICAL DATA.....	17
[13] PHYSICAL DIMENSIONS	19
[14] ELECTROMAGNETIC COMPATIBILITY (EMC)	21
[15] OTHER INFORMATION	23
[16] DISPOSAL	23
[17] LABEL LOCATION.....	24

[1] INTRODUCTION

1. GENERAL

This manual provides information for the operation and maintenance procedures and technical specifications for PHOT-X IIs 505 dental x-ray. The instructions contained in this book should be thoroughly read and understood before operation. PHOT-X IIs 505 has no user serviceable items. Repair should be performed by qualified dealer service personnel. Any part of this x-ray unit shall not be maintained or serviced while in use with a patient.

2. INTENDED PURPOSE

- a. PHOT-X IIs 505 is an extraoral source dental radiographic x-ray unit. This unit is an active device intended to generate and control diagnostic purpose ionizing radiation. The absorption pattern of x-ray beam recorded on intraoral image receptor is used for general-purpose, routine, dental radiography examinations of diseases of the teeth, jaw and oral cavity structures.
- b. Patient Population: All patients with oral diseases are eligible, without distinction as to age, gender, etc. However, infants/children who are unable to remain still during imaging or who are unable to hold the film, sensor, or other imaging device in their mouths are excluded from the scope.
- c. Intended Users: Qualified Healthcare Professionals trained in the use of the device, familiar with the use and application of x-ray imaging systems and the local x-ray protection requirements.

3. COMPONENTS IDENTIFICATION OF X-RAY SYSTEM “PHOT-X IIs 505”

- a. Tube housing assembly : 505-H
- b. X-ray controls : 505-CM (main controller), 505-CSL (LCD sub controller)
- c. Cones : 505-R (regular), 505-L (long)
- d. Collimator : 505-REC (rectangular)
- e. Balance arm : 505-A

4. CDECLARATION OF CONFORMITY

We declare PHOT-X IIs 505 x-ray unit complies with following regulation and directive.

MDR (Medical Device Regulation) : Regulation (EU) 2017/745 Annex II and III

RoHS Directive : 2011/65/EU category 8 of Annex I

5. CLASSIFICATION

5-1. According to Medical Device Regulation, PHOT-X IIs 505 is classified as CLASS IIb medical device by the rule 10 of MDR ANNEX VIII.

5-2. According to IEC60601-1, PHOT-X IIs 505 is classified as follows.

- a. Protection against electric shock : Class I Equipment
- b. Type of applied parts : Type B (RK type only)
- c. Protection against ingress of water : Ordinary
- d. Mode of operation : Non continuous (Duty Cycle = 1 : 30,
Max. ON time: 2.0 sec, Min. OFF time: 12 sec.)
- e. Equipment not suitable for use in the presence of a flammable anesthetic mixture with air or with oxygen or nitrous oxide.

6. NOTICE TO THE USER

- a. This X-ray unit may be dangerous to patient and operator unless safe exposure factors, operating instructions and maintenance schedules are observed.
- b. Only qualified and authorized personnel may operate this equipment observing all laws and regulations concerning protection. The operator must:
 - have means for audio and visual communication with the patient.
 - have full view of kV, mA, timer selections and exposure warning light.
 - be at least 2 m away from the x-ray head and patient and out of the path of the x-ray beam or be positioned behind a protective device.
 - fully use all radiation protection devices, accessories and procedures available to protect the patient and operator from x-ray radiation.
- c. Any serious incident occurred in relation to the device should be reported to the manufacturer and the competent authority of the Member State in which the user is established.
- d. This x-ray unit must be properly managed and used to meet the requirements of EU Directive 201 3/59/EU RATO M. For example, the annual radiation dose should be kept below the limit specified by the Directive. If the local laws or regulations are stricter than the Directive, the user shall comply with those laws or regulations.

7. SYMBOLS

In this book, on the labels or on the control panel of PHOT-X IIs 505 LCD, following symbols are used. Confirm the meanings of each symbol by the table below.

	Manufacturer		Date of manufacture		ON (POWER)		OFF (POWER)								
	Protection Grounding		Exposure Switch		X-ray Emission		Ready								
	Maxillary Incisor		Maxillary Cuspid & Pre Molar		Maxillary Molar		Maxillary Occlusal								
	Mandibular Incisor		Mandibular Cuspid & Pre Molar		Mandibular Molar		Mandibular Occlusal								
	Bite Wing (Incisor & Pre Molar)		Bite Wing (Molar)		Short Cone		Long Cone								
	Patient Child		Patient Adult		Patient Large Adult		Brightness of Backlight								
	Return		Loudness of Speaker		Mute		Level Control								
	Setting Mode		Store to Memory		Turn down		Turn up								
	Film		Digital Sensor		Phosphor Plate		Delete								
	Decrease		Increase		Wait		Protection against electric shock: Type B								
	Compliance with European directive required		Authorized Representative in The European Community		Serial Number		Catalogue Number								
	Separate Collection for Electrical and Electronic Equipment		Follow Instructions for use		Medical device		Type of the device								
	Identification for each component		Rated input to the device		Rated output from the device		Max. ON time: 2 second, Min. OFF time: 12 second								
	Manufactured in Japan (used with date symbol)		Brand symbol of Takara Belmont group		Weight of whole unit		Electronic instructions for use								
	X-ray tube		Source to skin distance	<p>FOCAL SPOT VALUE : 0.4</p> <p>INHERENT FILTRATION : 1.7 mmAl Equiv</p> <p>ADDED FILTRATION : 0.3 mmAl</p> <p>TOTAL FILTRATION : 2.0 mmAl Equiv.</p> <p>RADIATION LEAKAGE RATE : 109 µ Gy/H at 1m</p>		<p>FOCAL SPOT VALUE</p> <p>INHERENT FILTRATION</p> <p>ADDED FILTRATION</p> <p>TOTAL FILTRATION</p> <p>RADIATION LEAKAGE RATE</p>									
	X-ray field size at cone end	Power supply requirements		<p>CAUTION DO NOT MOVE ENTIRE X-RAY UNIT WITH ARM EXTENDED</p> <p>ATTENTION NE PAS DEPLACER L'APPAREIL COMPLET AVEC SON BRAS ETENDU.</p>		<p>CAUTION DO NOT MOVE ENTIRE X-RAY UNIT WITH ARM EXTENDED.</p>									
<table border="1"> <thead> <tr> <th>PHOT-X IIs</th> <th>Power supply requirements</th> </tr> </thead> <tbody> <tr> <td>Rated Voltage [Vac]</td> <td>100 110 120 220 230 240</td> </tr> <tr> <td>Max Apparent Resistance [Ω]</td> <td>0.39 0.45 0.52 0.91 0.98 1.06</td> </tr> <tr> <td>Over Current Release [A]</td> <td>≥15 ≥10</td> </tr> </tbody> </table>		PHOT-X IIs	Power supply requirements	Rated Voltage [Vac]	100 110 120 220 230 240	Max Apparent Resistance [Ω]	0.39 0.45 0.52 0.91 0.98 1.06	Over Current Release [A]	≥15 ≥10	<p>Rated Voltage [Vac]</p> <p>Max Apparent Resistance [Ω]</p> <p>Over Current Release [A]</p>		<p>CAUTION ! DO NOT RELEASE THIS BAND UNTIL X-RAY HEAD IS INSTALLED.</p>		<p>WARNING Keep casters in the lock position, unless moving the equipment. To avoid injury, do not push or lean on the equipment.</p>	
PHOT-X IIs	Power supply requirements														
Rated Voltage [Vac]	100 110 120 220 230 240														
Max Apparent Resistance [Ω]	0.39 0.45 0.52 0.91 0.98 1.06														
Over Current Release [A]	≥15 ≥10														

[2] MAJOR COMPONENTS

1. MOBILE TYPE (FM)

- ① Main Power Switch
- ② X-Ray Head
- ③ Cone
- ④ Yoke
- ⑤ Arm Collar
- ⑥ Balance Arm
- ⑦ Pole Bush
- ⑧ Pole
- ⑨ Pole Base
- ⑩ Leg Bar (long)
- ⑪ Leg Bar (Short)
- ⑫ Lock Caster
- ⑬ Standard Caster
- ⑭ Main Controller
- ⑮ Sub Controller
- ⑯ Hand Exposure Switch

⚠ WARNING

Keep casters in the lock position, unless moving the equipment. To avoid injury, do not push or lean on the equipment.

⚠ CAUTION

Do not move entire x-ray unit with arm extended.

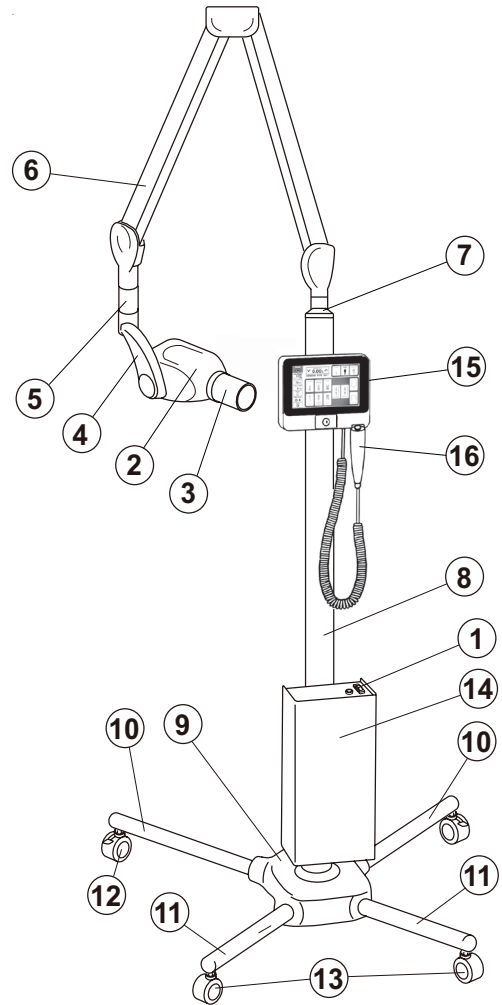

Fig.2-1 Major Components for FM

2. ROOM MOUNT TYPE (RK)

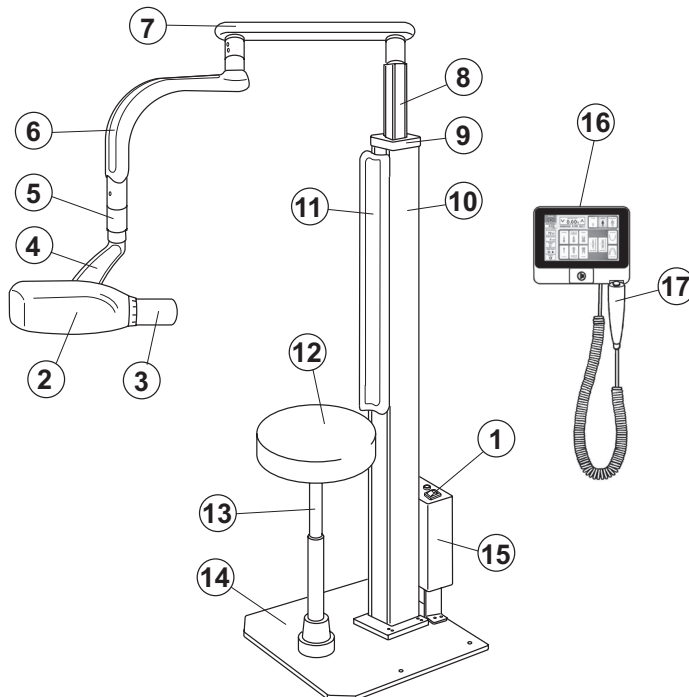

Fig.2-2 Major Components for RK

- ① Main Power Switch
- ② X-Ray Head
- ③ Cone
- ④ Yoke
- ⑤ Arm Collar
- ⑥ Swing Arm 1
- ⑦ Swing Arm 2
- ⑧ Sliding Post
- ⑨ Column Cover
- ⑩ Column
- ⑪ Backrest Cushion (applied part)
- ⑫ Seat (applied part)
- ⑬ Gas Cylinder
- ⑭ Base Plate
- ⑮ Main Controller
- ⑯ Sub Controller
- ⑰ Hand Exposure Switch(option)

3. FLOOR MOUNT TYPE (FK)

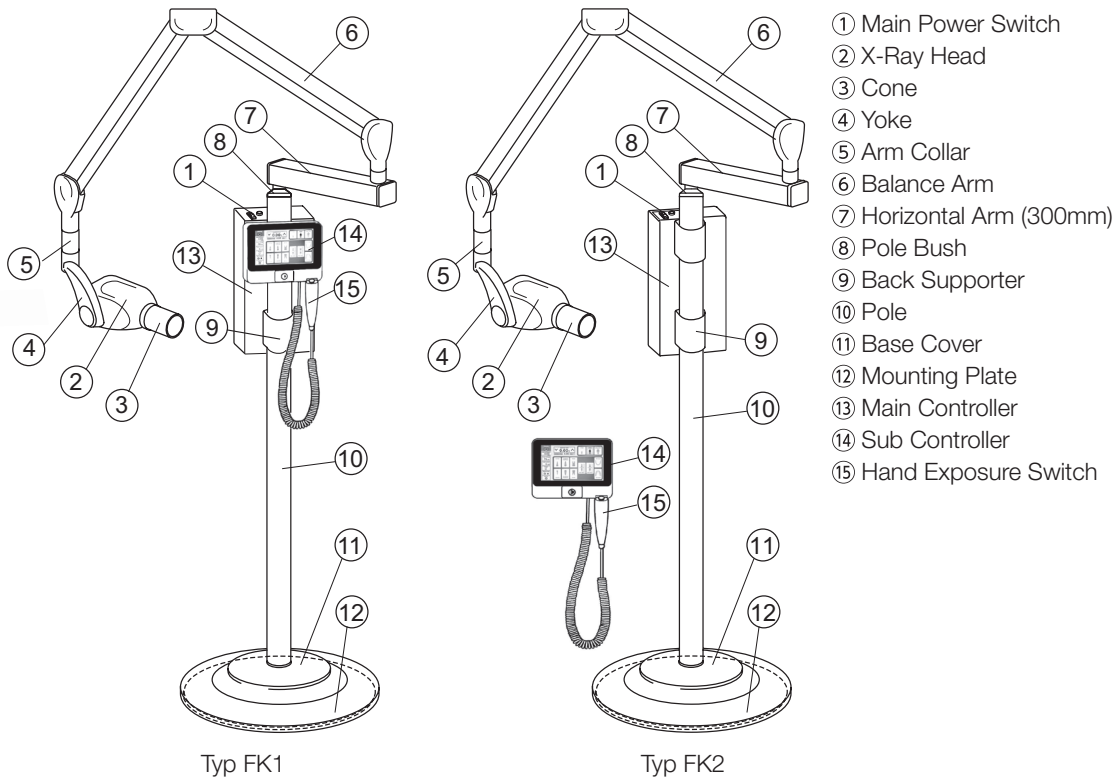

Fig.2-3 Major Components for FK1/FK2

4. CEILING MOUNT TYPE (CK)

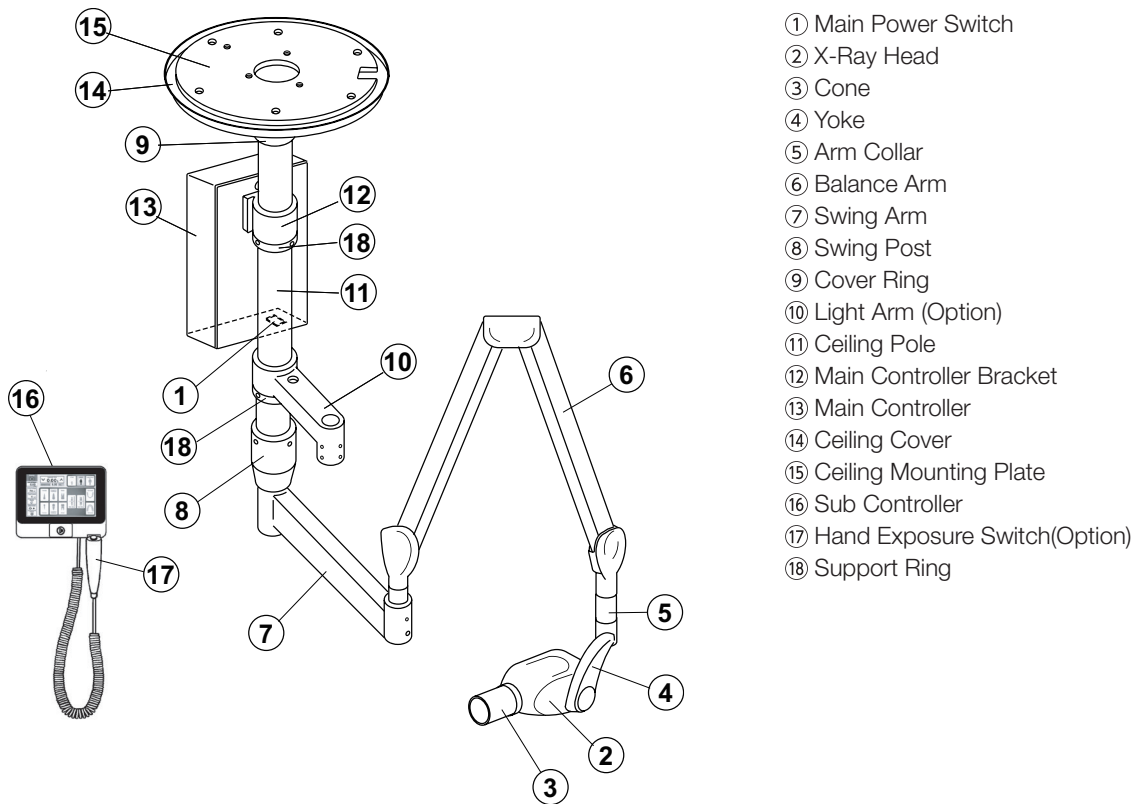

Fig.2-4 Major Components for CK

5. WALL MOUNT TYPE (WK)

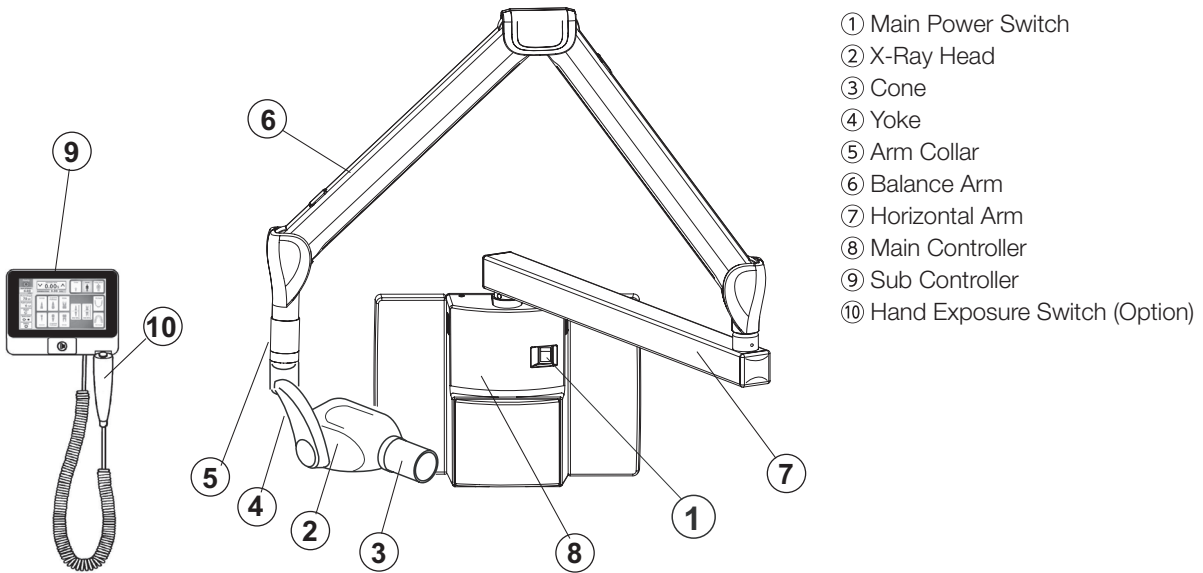
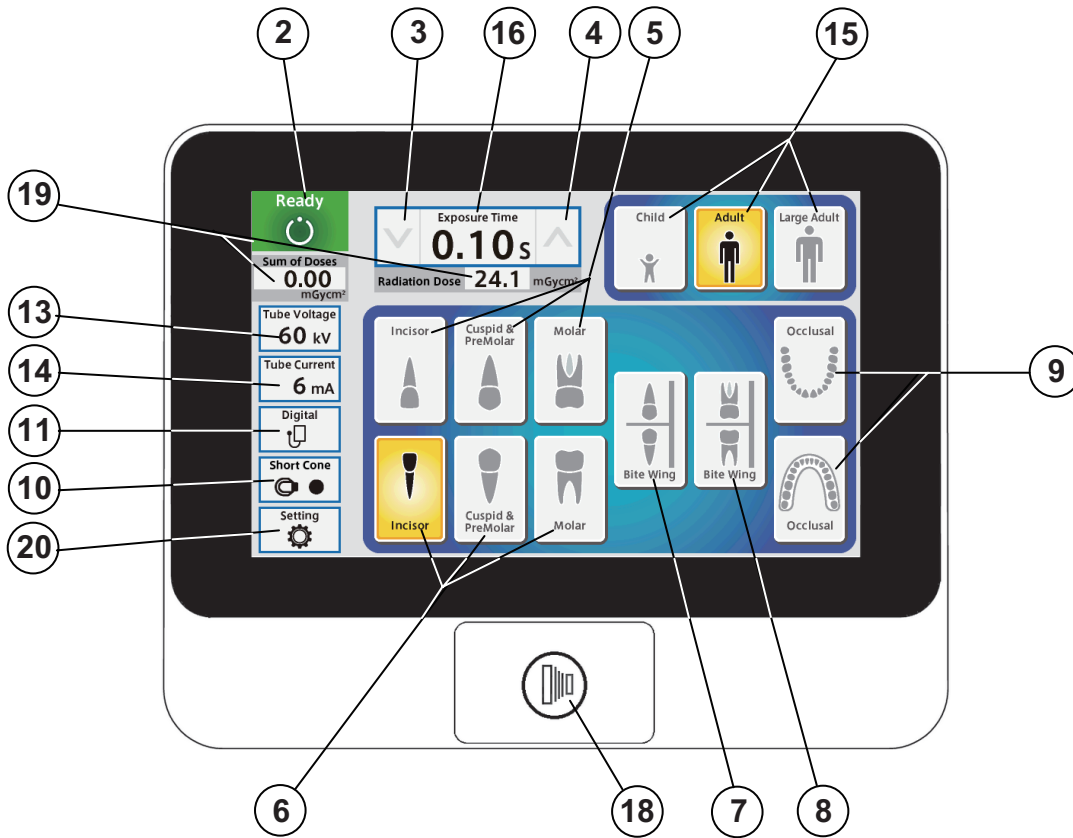
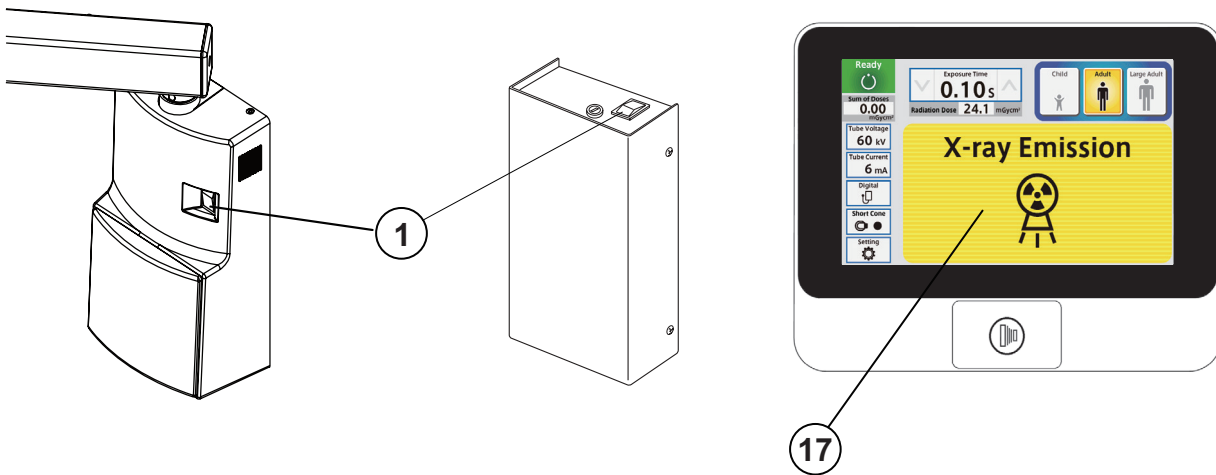

Fig.2-5 Major Components for WK

[3] LAYOUT OF CONTROLS



- ① Main Power Switch
- ② Ready Indication
- ③ Exposure Time Adjustment Switch (Down)
- ④ Exposure Time Adjustment Switch (Up)
- ⑤ Tooth Selection Switch (Maxilla)
- ⑥ Tooth Selection Switch (Mandible)
- ⑦ Tooth Selection Switch (Bitewing)
- ⑧ Tooth Selection Switch (Bitewing Molars)
- ⑨ Tooth Selection Switch (Occlusal)
- ⑩ Cone Type Selection Switch
- ⑪ Image Receptor Selection Switch
- ⑫ is intentionally omitted
- ⑬ kV Selection Switch
- ⑭ mA Selection Switch
- ⑮ Patient Size Selection Switch
- ⑯ Exposure Time Display Window
- ⑰ Exposure Warning Indication (on the next page)
- ⑱ Exposure Switch
- ⑲ Radiation Dose Indication
- ⑳ Setting Mode Switch



[4] FUNCTION OF CONTROLS

① Main Power Switch

Pushing the upper side of this switch to the ON position energizes the x-ray unit.

② Ready Indication

This indication becomes green when the exposure time is set and the line voltage is within operable range (207 ~ 253Vac). When this indication is white, exposure cannot be made.

③ ④ Exposure Time Adjusting Switches

By momentarily touching the \wedge (or \vee) switch, the exposure time displayed increases (or decreases) by one increment. By keeping the switch touched more than 2 sec., the exposure time displayed increases (or decreases) continuously until the switch is released. PHOT-X IIs 505 has the following 37 exposure time settings:

Model 505 has the following 37 exposure time settings:

0.00, 0.01, 0.02, 0.03, 0.04, 0.05, 0.06, 0.07, 0.08, 0.09, 0.10, 0.11, 0.13, 0.14, 0.16, 0.18, 0.20, 0.22, 0.25, 0.28, 0.32, 0.36, 0.40, 0.45, 0.50, 0.56, 0.63, 0.71, 0.80, 0.90, 1.00, 1.12, 1.25, 1.40, 1.60, 1.80, 2.00 (sec.)

⑤ ~ ⑨ Tooth Selection Switches

Touching one of these switches sets the exposure time to the optimum value according to the tooth type and the following settings (⑩ ~ ⑮). Selected tooth is illuminated in orange.

- ⑤ Maxilla : Incisor, Cuspid & Premolar or Molar
- ⑥ Mandible : Incisor, Cuspid & Premolar or Molar
- ⑦ Bitewing : Incisor and Cuspid & Premolar
- ⑧ Bitewing : Molar
- ⑨ Occlusal : Maxilla and Mandible

If Incisor of Mandible switch is touched more than 3 sec., unit will go into the screen saver mode and touch switch is disabled. To return to normal mode, touch any part on the LCD screen more than 3 sec.

⑩ Cone Type Selection Switch

This switch indicates the cone type being selected at the time. Momentarily touching this switch will open the cone type selection window. This window when one of cones is selected.

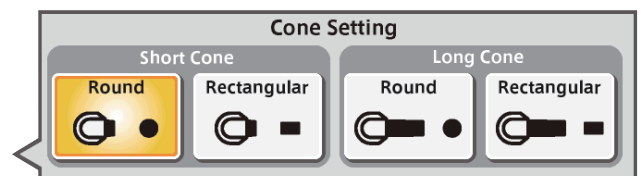

Cone type selection window

⑪ Image Receptor Selection Switch

To get optimal images the exposure timer adjustment according to the sensitivity of image receptor is important. The PHOT-X IIs 505 has 16 density settings for each three kinds of image receptors, i.e. film, digital sensor and phosphor plate. For film, two different sensitivities can be selected as film-a and film-b and those can be switched easily.

(1) Film

Following two speed (=sensitivity) settings are pre-set at the factory.

a = Film speed No. F.09 (equivalent to ISO speed group "D", or Kodak Ultra-Speed film)

b = Film speed No. F.05 (equivalent to ISO speed group "F/E", or Kodak InSight film)

Including these two speeds, the PHOT-X IIs 505 x-ray can provide 16 different film speeds (F.00 ~ F.15) and any two of them can be programmed as film-a and film-b.

Film speed number being selected at the time can be confirmed by touching switch ⑪. If doctor uses a different film speed, or prefers darker (or lighter) radiographs, the new speed can be programmed as follows. Larger speed number makes films darker. If film speed number is increased by 1, exposure time becomes 25 % longer. The method to change the film speed setting is as follows.

1. Go to the setting mode by touching the switch ⑩.
2. Select "Image receptor sensitivity setting" at page 2/3 in "Setting mode".
3. If new film is used, select the "Preset setting", select "film-a" or "film-b" and select the manufacturer and model name of the film.
4. If darker (or lighter) radiographs are preferred or film name is not listed in "Preset setting", select the "Manual setting" and by touching Ⓐ or Ⓑ switch, increase or decrease film speed until the desired number is displayed. Touch the memory icon to store the setting.

(2) Digital sensor and Phosphor Plate

If a digital imaging system is used, shorter exposure time is often required compared with film. PHOT-X IIs LCD has 16 speeds for digital sensor and phosphor plate (d.00 ~ d.15).

Factory settings for digital sensor and phosphor plate are both d.10, but it is necessary to change according to the sensitivity of each model of digital sensor or phosphor plate. The density number selected can be checked by touching switch ⑪. The method to change the density setting for digital sensors or phosphor plate is same as film.

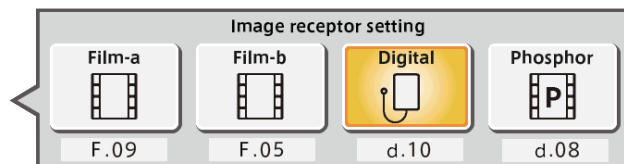

Image Receptor selection window

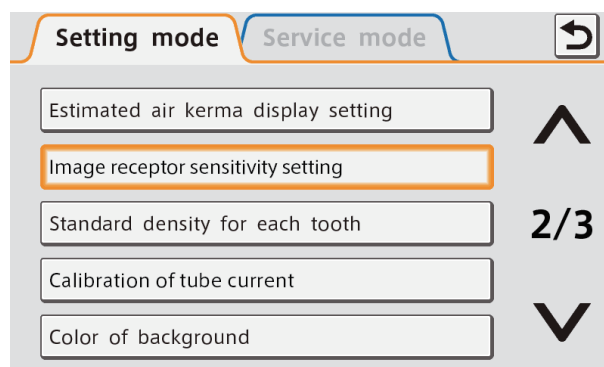
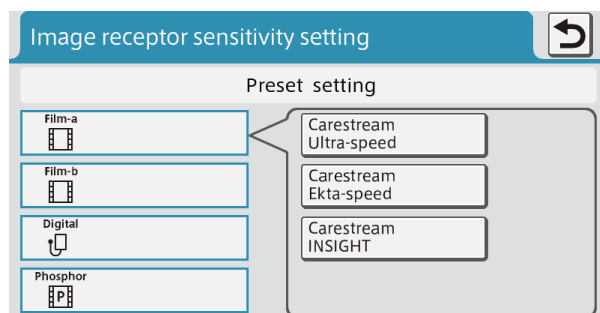
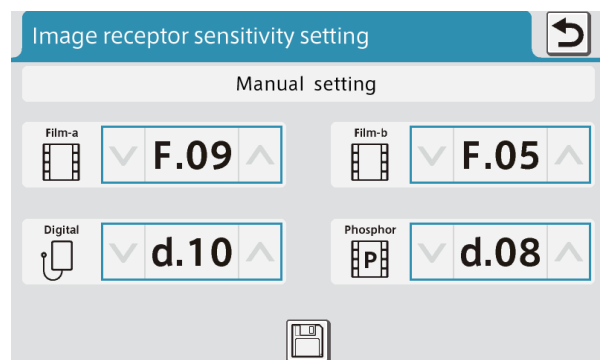

Image Receptor sensitivity setting



Preset setting mode



Manual setting mode

TABLE 1. Speed Setting and Exposure Time (Short Cone)

[unit : sec.]

Speed Setting	kV	mA	Child					Adult					Large Adult				
			T1	T2	T3	T4	T5	T1	T2	T3	T4	T5	T1	T2	T3	T4	T5
F.09	60	3	0.20	0.25	0.28	0.32	0.50	0.32	0.40	0.50	0.56	0.80	0.40	0.50	0.63	0.71	1.00
		6	0.10	0.11	0.14	0.16	0.25	0.16	0.20	0.25	0.28	0.40	0.20	0.25	0.28	0.36	0.50
	70	3	0.14	0.16	0.20	0.22	0.36	0.25	0.28	0.36	0.40	0.56	0.28	0.36	0.45	0.50	0.71
		6	0.07	0.08	0.10	0.11	0.18	0.11	0.14	0.18	0.20	0.28	0.14	0.18	0.22	0.25	0.36
F.05	60	3	0.08	0.10	0.11	0.14	0.20	0.14	0.16	0.20	0.22	0.32	0.18	0.20	0.25	0.28	0.40
		6	0.04	0.05	0.06	0.07	0.10	0.07	0.08	0.10	0.11	0.16	0.09	0.10	0.13	0.14	0.20
	70	3	0.06	0.07	0.08	0.10	0.14	0.10	0.11	0.14	0.16	0.25	0.13	0.14	0.18	0.20	0.28
		6	0.03	0.04	0.04	0.05	0.07	0.05	0.06	0.07	0.08	0.11	0.06	0.07	0.09	0.10	0.14
F.10	60	3	0.13	0.14	0.18	0.20	0.28	0.20	0.25	0.28	0.36	0.50	0.25	0.32	0.36	0.40	0.63
		6	0.06	0.07	0.09	0.10	0.14	0.10	0.13	0.14	0.16	0.25	0.13	0.16	0.18	0.22	0.32
	70	3	0.09	0.11	0.13	0.14	0.22	0.14	0.18	0.22	0.25	0.36	0.18	0.22	0.25	0.32	0.45
		6	0.04	0.05	0.06	0.07	0.11	0.07	0.09	0.11	0.13	0.18	0.09	0.11	0.13	0.16	0.22

TABLE 2. Speed Setting and Exposure Time (Long Cone)

[unit : sec.]

Speed Setting	kV	mA	Child					Adult					Large Adult				
			T1	T2	T3	T4	T5	T1	T2	T3	T4	T5	T1	T2	T3	T4	T5
F.09	60	3	0.40	0.50	0.63	0.71	1.00	0.71	0.80	1.00	1.12	1.60	0.90	1.00	1.25	1.40	2.00
		6	0.20	0.25	0.28	0.36	0.50	0.36	0.40	0.50	0.56	0.80	0.45	0.50	0.63	0.71	1.00
	70	3	0.28	0.36	0.45	0.50	0.71	0.50	0.56	0.71	0.80	1.25	0.63	0.71	0.90	1.00	1.40
		6	0.14	0.18	0.22	0.25	0.36	0.25	0.28	0.36	0.40	0.56	0.32	0.36	0.45	0.50	0.71
F.05	60	3	0.18	0.20	0.25	0.28	0.40	0.28	0.36	0.40	0.45	0.71	0.36	0.45	0.50	0.56	0.90
		6	0.09	0.10	0.13	0.14	0.20	0.14	0.18	0.20	0.25	0.36	0.18	0.22	0.25	0.28	0.45
	70	3	0.13	0.14	0.18	0.20	0.28	0.20	0.25	0.28	0.32	0.50	0.25	0.32	0.36	0.40	0.63
		6	0.06	0.07	0.09	0.10	0.14	0.10	0.13	0.14	0.16	0.25	0.13	0.16	0.18	0.22	0.32
F.10	60	3	0.25	0.32	0.36	0.45	0.63	0.45	0.50	0.63	0.71	1.00	0.56	0.63	0.80	0.90	1.25
		6	0.13	0.16	0.18	0.22	0.32	0.22	0.25	0.32	0.36	0.50	0.28	0.32	0.40	0.45	0.63
	70	3	0.18	0.22	0.28	0.32	0.45	0.32	0.36	0.45	0.50	0.71	0.40	0.45	0.56	0.63	0.90
		6	0.09	0.11	0.13	0.16	0.22	0.16	0.18	0.22	0.25	0.36	0.20	0.22	0.28	0.32	0.45

⑬ **kV Selection Switch**

Momentarily touching this switch will open the kV selection window. This window closes when either 60 or 70 kV is selected.

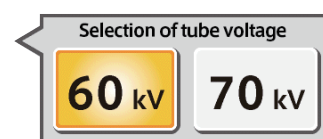

kV Selection Window

⑭ **mA Selection Switch**

Momentarily touching this switch will open the mA selection window. This window closes when either 3 or 6 mA is selected.

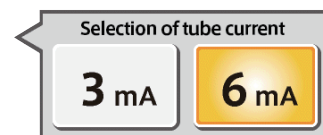

mA Selection Window

⑮ **Patient Selection Switch**

These switches alter the selection of patient type/size to be radiographed (child, adult or large adult) and sets the exposure time automatically. If the weight of child is less than 20kg, touch switch once after setting to child. If the weight of child is over 50kg and less than 70kg, touch switch twice after setting to child. If the weight of child is over 70kg, set to adult.

NOTE: Setting or adjusting the exposure time manually (with or switch) supersedes ⑤ ~ ⑮ functions.

⑯ **Exposure Time Display Window**

This window displays the selected exposure time.

⑰ Exposure Warning Indication

This indication appears while the unit is producing x-radiation.

⑱ Exposure Switch

This switch initiates radiographic exposure. When making an exposure, depress and hold this switch until the Exposure Warning Indication ⑰ and the audible warning shut off. Failure to keep this switch depressed will result in the premature termination of the exposure and an error code E.00 will be displayed.

⑲ Radiation Dose Indication

Estimated air kerma (radiation dose) at distal end of cone can be displayed below the exposure time display window. This value is calculated by kV, mA, exposure time and cone type selected at the moment. The value displayed below the ready indication is sum of estimated air kerma of each exposure after the power switch has been turned on.

The units of these values can be selected from mGy or mGycm². And also to display these values or not can be selected by the following procedures.

1. Go to the setting mode by touching switch ⑳.
2. Select "Estimated air kerma display setting" at 2/3 page of setting mode.
3. Select "Display ON" or "Display OFF".
4. If "Display ON" is selected, you can select "mGy" or "mGycm²" on next menu.

㉑ Setting Mode Switch

By touching this switch the normal operation mode will be changed to the setting mode or service mode. At the setting mode, following settings can be changed. Refer to section [5] for detail. Service mode is restricted to the qualified dealer service personnel and requires password.

Page 1/3: Parameter selection at power ON

- Volume control
- Brightness of LCD
- Sensitivity of touch panel
- Language selection

Page 2/3: Estimated air kerma display setting

- Image receptor sensitivity setting
- Standard density for each tooth
- Calibration of tube current
- Color of background

Page 3/3: Screen saver setting

- Nameplate setting
- Photo display setting

[5] OPERATING PROCEDURES

1. Turn ON the Main Power Switch ①.

NOTE: Do not turn on the main power switch while touching the LCD screen, as the touch sensor initializes the sensitivity when the power is turned on.

2. Select the appropriate tooth type (⑤ ~ ⑨), and confirm the pre-selected conditions (cone type, film or digital, kV, mA and patient size) are suitable for exposure.

NOTE: To manually set the exposure time, depress either of the Manual Exposure Time Adjusting Switches (⤴ or ⤵) until the desired exposure time appears in the Exposure Time Display Window ⑩. While the unit is in manual mode, other selection switches (⑤ ~ ⑮) do not affect exposure time. (All of the tooth selection switches are white.) To return to the automatic exposure time selection mode, depress any one of Tooth Selection Switches (⑤ ~ ⑨).

3. Confirm that Ready Indication ② is illuminated on green.

NOTE: The ready indication will not illuminate unless the incoming line voltage is correct and within the x-ray's operable range (207 ~ 253Vac).

4. Set the image receptor in the patient's mouth and position the x-ray tubehead using the standard positioning procedures.
5. Depress the Exposure Switch ⑰. When the Exposure Switch is depressed, the Exp. Warning Indication ⑱ appears and the audible warning sounds. Do not release the Exposure Switch until the Exposure Warning Indication and audible warning automatically shut off. Failure to keep the switch depressed will result in exposure being terminated prematurely.
6. To continue to radiograph other teeth, just select appropriate Tooth Selection Switches (⑤ ~ ⑨).

IMPORTANT: To protect x-ray tube head from heat accumulation, wait for a time interval that is equal to 30 times the selected exposure time before making additional exposures. (Example : a 15 sec. wait is necessary between exposures that are 0.5 sec. in duration.)

7. Turn OFF the Main Power Switch ① in order to prevent accidental exposures when the unit is not in use.

NOTE: If the unit is left without being operated and the Main Power Switch ① is kept on, display will go into one of the following four screen saver modes.

- a. Energy saving mode
- b. Fixed display of one photo
- c. Slide-show of photos
- d. Nameplate display

Transition time to the screen saver mode can be set by 5-minute steps and making switch enable or disable during screen saver mode is also selectable.

[6] SETTING MODE

By touching the setting mode switch at bottom left corner, the normal operation mode can be changed to the setting mode or service mode. There are 13 setting modes and each purposes of those settings are as follows.

1. Parameter selection at power ON

Factory default settings are

- kV selection : 60 kV
- mA selection : 6 mA
- Image receptor : Digital sensor
- Patient type : Adult
- Cone type : Short cone (round)

If necessary, these settings can be changed. For example, in case of pedodontistry, patient type should be changed to Child. For the image receptor, as the sensitivity of each receptor is different, please set the sensitivity as shown page 7. If the same settings before the power switch is turned off could be set at power on, select "Same Selection before Power OFF".

2. Volume control

Volume of touch screen sound and warning sounds can be adjusted separately. One from 9 levels including off setting can be selected for touch screen sound and one from 3 levels for warning sounds. Warning sounds are for exposure warning and error warning.

3. Brightness of LCD

Brightness for backlight of LCD display can be selected from 10 levels.

4. Sensitivity of touch panel

Sensitivity of touch switch on the panel can be selected from 3 levels.

5. Language selection

Language can be selected from English, French, Spanish or German.

NOTE : For products shipped to France, Italian is installed instead of German.

6. Estimated air kerma display setting

Whether to display the estimated air kerma (radiation output) or not to display can be selected. If displaying is selected, the unit of the values can be selected from mGy or mGycm².

7. Image receptor sensitivity setting

Manual setting or preset setting can be selected.

Manual setting: Two film speeds can be selected from 16 speeds as film-a and film-b. One digital sensor sensitivity can be selected from 16 steps and one phosphor plate sensitivity can be selected from 16 steps. Refer to page 7 for detail.

Preset setting: For each 4 types of image receptors, standard sensitivity can be set by selecting the manufacturer and model name of the image receptor.

8. Standard density for each tooth

The exposure time ratio between each tooth is preprogrammed. This ratio can be changed by this setting. Exposure time for each tooth can be increased (or decreased) by 4 steps individually. One step increase is corresponding to 25% increase of exposure time.

9. Calibration of tube current

Tube current can be adjusted to be the rated value by making several exposures at this mode.

It is necessary at the installation and at the annual maintenance checks.

10. Color of background

The default color of the back panel at the normal operation mode is blue. This color can be changed to green or pink. And also there are two patterns for pink.

11. Screen saver setting

If the unit is left without being operated and the main power switch is kept on, display will go into screen saver mode. You can select one of following four kinds of screen saver modes.

- a. Energy saving mode: Backlight of LCD becomes minimum in this mode.
- b. Fixed display of one photo: One of ten photos pre-stored is displayed. You can overwrite your original photos on the pre-stored photos.
- c. Slide-show of photos: ten photos are displayed in turn continuously.
- d. Nameplate display: Any name within 20 characters with a photo is displayed.

Transition time from normal mode to the screen saver mode can be set to 5 ~ 30 minutes in 5-minutes steps. Enabling or disabling of touch switch function during screen saver mode is also selectable.

12. Nameplate setting

Nameplate creation: Four kinds of nameplates can be created and stored. To check the nameplate already created, touch the mountain icon at right side. To modify or create new name, touch the name or "New Name Input" at left side.

Maximum 20 characters can be used for the name of nameplate. After the name is fixed, you can use preinstalled photo or your original photo for that nameplate. If you want to use your own photo, USB flash drive containing your photo data should be connected to the right side connector of LCD controller. The file name of your photo should be the same as indicated on the screen and data format should be 16 bit or 24 bit BMP with 800 x 400 pixels.

Nameplate selection: One of the nameplates created should be selected for the screen saver mode.

13. Photo display setting

Ten photos are pre-stored. One of ten photos is used for "fixed display of one photo" and ten photos are used for "Slide-show of photos" at screen saver mode.

Stored photo can be checked by touching the mountain icon at right side. If you want to store your own photo, touch one of the bar named "FF00" to "FF09". Connect USB flash drive containing your photo data to the right side connector of LCD controller. The file name of your photo should be the same as indicated on the screen and data format should be 16 bit or 24 bit BMP with 800 x 480 pixels.

[7] OPTIONAL HAND EXPOSURE SWITCH

An optional hand exposure switch can be connected to the sub controller. Since this exposure switch has a coiled cord, operators can stand in the most suitable position for operation. As controller has separate connector for this exposure switch, both exposure switch ⑱ on the front panel of sub controller and this hand exposure switch can be used. If local code prohibits use of both, ask installer to disconnect the connector of either switch.

[8] DIGITAL IMAGING SYSTEM

No x-ray image receptor is integrated into the PHOT-X IIs 505 x-ray system. If a receptor for digital imaging is used with PHOT-X IIs 505, the type and performance of the image receptor should be as follows.

1. Type of receptor: CCD (charge-coupled device), CMOS (complementary metal oxide semiconductor) or PSP (photostimulable phosphor plate) receptor for dental intraoral use.
2. Adequate dose of x-radiation for the receptor should be between 0.02mGy and 23.6mGy.
3. Use the receptor holder and receptor cover recommended by the manufacturer of image receptor.
4. Receptor holder should hold the image receptor firmly in position and work as the x-ray beam alignment device.

WARNING

The use of ACCESSORY equipment not complying with the equivalent safety requirements of the PHOT-X IIs 505 may lead to a reduced level of safety of the resulting system.

Consideration relating to the choice shall include:

- accessory should be CE marked
- evidence that the safety certification of the ACCESSORY has been performed in accordance to the appropriate IEC60601-1 and IEC60601-1 harmonized national standard.

[9] INFECTION CONTROL AND CLEANING

1. INFECTION PREVENTION

X-ray operators are required to wear disposable gloves when taking radiographs and handling contaminated film packets or digital detector cover. Gloves should be changed for each patient to avoid cross contamination. X-ray head, main controller and sub controller should be covered by single use barriers.

CAUTION

If holders for film or digital detector are used, properly sterilize them according to the procedures indicated by each manufacturer of holders.

2. CLEANING

In order to ensure proper hygiene and cleaning of the equipment, the following procedures must be followed.

CAUTION

Before cleaning the unit, turn off the main power switch and breaker on the branch line. This is required because some internal parts remain connected to main voltage even when the main power switch has been turned off.

Never use the corrosive disinfectants, such as povidone iodine or sodium hypochlorite. Do not pour or spray solvent or liquid directly on the x-ray unit.

Be careful not to allow solvents to run or drip into the x-ray unit.

- a. Turn off the main power switch and breaker on the branch line.
- b. Wipe the outside surface with a paper towel dampened with a disinfectant solution or household, non-abrasive cleaner.
Recommended disinfectant : FD333 (Durr Dental GmbH)
- c. Allow surface to air dry before turning breaker and main switch back on.

[10] ERROR CODES

If an abnormal condition exists in the unit, or a malfunction occurs, an error code, code condition, and the possible solution will be displayed on the LCD screen. Please refer to the table below.

Error Code	Condition	Step to be Taken	Possible Solution
E.00	Exposure switch was released before exposure termination.	All the tooth selection lights blink. Touch one of the tooth switches.	Release the exposure switch after the exposure warning indication disappears.
E.01	Exposure switch was pressed within 10 sec. of previous exposure.	A 10 sec. delay is built in between each exposures and 3 sec. delay is built in after the power is on.	There should be a "wait" interval of 30 times the exposure time between successive exposures.
	Exposure time was set and exposure switch was pressed within 3 sec. after the power switch being turned on.		Wait for a minimum 3 sec. after the main power switch is turned on before pressing the exposure switch.
E.02	Line voltage was less than 90% of rated voltage.	Line voltage should be in the range of $\pm 10\%$ of rated voltage.	Confirm that ready lamp is on before exposure. Ask service personnel to check the line voltage.
E.03	Line voltage was more than 110% of rated voltage.		
E.05	Tube current at last portion of exposure was less than 2 mA at 3 mA setting or less than 4.5 mA at 6 mA setting	Turn off the main power switch and wait for approximately 2 min. Turn on the main power switch again.	If same error code is displayed, call service personnel.
E.06	Tube current at last portion of exposure was more than 4 mA at 3 mA setting or more than 7.5 mA at 6 mA setting		
E.07	During the exposure, tube current becomes less than 1.5 mA at 3mA setting or less than 3 mA at 6 mA setting.		
E.08	During the exposure, tube current becomes more than 14 mA.		
E.09	Setting for pre-heating time is out of range.		
E.10	Exposure switch or exposure circuit had been ON, when main power switch is turned on.		
E.11	Tube current is detected during preheating period.		
E.12	Tube current is detected when main power switch is turned on.		
E.14	Tube potential at last portion of exposure was less than 50 kV at 60 kV setting or less than 60 kV at 70 kV setting.		
E.15	Tube Potential at last portion of exposure was more than 70 kV at 60 kV setting.		
E.16	1. During the exposure, tube potential becomes less than 40 kV at 60 kV setting or less than 50 kV at 70 kV setting.		
	2. 2P connector between the main power board and arm or between the arm and tube head is disconnected.		

Error Code	Condition	Step to be Taken	Possible Solution
E.17	During the exposure, tube potential becomes more than 80 kV.	Turn off the main power switch and wait for approximately 2 min. Turn on the main power switch again.	If same error code is displayed, call service personnel.
E.18	Excess current was detected in primary circuit of filament transformer.		
E.19	Excess current was detected in primary circuit of high voltage transformer.		
E.20	1. Exposure switch was depressed when tube head temperature was over 60 C. 2. 8P connector between the main power board and arm or between the arm and tube head is disconnected.	Wait until the temperature goes down.	
E.22	Failure of electrical communication between the power PCB and timer PCB.	Turn off the main power switch and wait for approx. 2 min. Turn on power switch again.	
E.23	Some switch had been on, when the main power switch is turned on. (Except the exposure switch.)		
E.24	The built-in battery has run out.		

[11] MAINTENANCE

The PHOT-X IIs 505 x-ray unit requires post installation confirmation and periodic maintenance checks to be performed by dealer service personnel. These procedures ensure that the x-ray unit is functioning within the manufacture's specifications and remains in compliance with the standard.

It is responsibility of the owner of the unit to see that these maintenance checks are correctly performed. The specific instructions to perform these checks are located within the PHOT-X IIs 505 Installation manual.

If it is required by local regulations, make inspectors conduct periodic testing and submit reports as required

- a. Maintenance personnel: Qualified dealer service personnel who has the experience with Belmont's x-ray or has been trained by Belmont. But item 7 - 14 of the maintenance check list on Page 16 should be verified routinely by treatment room personnel.
- b. Specification of the parameters to be monitored and monitoring frequency: Refer to the maintenance check list on page 16.
- c. Acceptance limit: Refer to the Maintenance check list on page 16.
- d. Required action when failed: Refer to the Maintenance check list on page 16.
- e. Tools to maintain quality control logs: Use the check list on page 16.
- f. Training material: Operator's instructions, Installation manual and Service manual

MAINTENANCE CHECK LIST

Parameter	Acceptance limit	Frequency	Procedures when failed	OK/NG
1. Line voltage	Confirm the line voltage is within 230V±10%. Also confirm the voltage drop during exposure is within 3%.	Yearly	Connect to the power supply within 230V±10%. Check disconnection of wire or connection failure. Repair cable connection as needed.	
2. Tube current	Confirm the measured mA value indicated on the LCD screen is within the rated value ± 1 mA.	Yearly	Perform MA adjustment. (Refer to installation instructions.)	
3. Tube potential	Confirm the measured kV value indicated on the LCD screen is within the rated value ±10%.	Yearly	Check the tube potential compensation (CP) values are same as the values on the label in the head yoke.	

Parameter	Acceptance limit	Frequency	Procedures when failed	OK/NG
4. Mounting plate for wall (WK), ceiling (CK) or floor (FK1/FK2)	Confirm the plate is firmly fixed to the wall (WK), ceiling (CK) or floor (FK1/FK2).	Yearly	If bolts are loose, find the reason why bolts became loose and take counter measure that prevents bolts become loose.	
5. Arm mounting bracket (WK)	Make sure that the arm bracket is firmly attached to the wall or wall plate.	Yearly		
6. Pole (FK1/FK2, CK)	Make sure the pole is securely attached to the mounting plate.	Yearly		
7. Dosimetry	Save the image that was taken under appropriate conditions as a reference image. Compare a newly taken image with a reference image to assure the image quality.	Weekly	If the image quality is found poor comparing to a reference image, check the condition of image receptor (film, sensor or imaging plate), image developer (developing fluid, dental film developer, PC or scanner).	
8. Horizontal arm (WK, FK1/FK2)	Confirm that horizontal arm is firmly inserted to the arm bracket. Make sure the retaining bolt is firmly inserted to the arm bracket.	Daily (before use)	If the retaining bolt is loose, find the reason why bolt became loose, take counter measure that prevent the retaining bolt become loose.	
9. Head	Confirm the head can be smoothly positioned.	Daily (before use)	Adjust the brake screws by referring to installation instructions.	
10. Vertical movement of balance arm	Confirm the balance arm moves smoothly without making noise.	Daily (before use)	Adjust the tension of the balance arm by referring to installation instructions. If the balance arm makes noise, apply grease.	
11. Swing angle of balance arm (FM)	Confirm the balance arm swings between two long legs.	Daily (before use)	Check the stopper screws and mounting screws of pole bushing.	
12. Caster (FM)	Confirm all casters move smoothly and lock function works fine by two lock casters.	Daily (before use)	Clean up the casters or replace them.	
13. Sliding post (RK)	Confirm the post slides smoothly.	Daily (before use)	Check the rollers of sliding post.	
14. Swing arm (CK, RK)	Confirm the joints of the swing arms are connected firmly and stopper and friction are adequate.	Daily (before use)	Check the keys, stopper ring, stopper screws and brake screw of swing arm, and change them as necessary.	

[12] TECHNICAL DATA

1. X-ray tube-----D-046 (Stationary Anode)
 - a. Nominal focal spot value-----0.4
 - b. Target Material-----Tungsten
 - c. Target angle-----12.5 deg
 - d. Maximum anode heat content -----4.3 kJ (6.1 kHU)
2. Maximum x-ray tube assembly heat content -----293 kJ (413 kHU)
3. Rated peak tube potential-----60 kV / 70 kV selectable
4. Rated tube current -----3 mA / 6 mA selectable
5. Maximum rated peak tube potential-----70 kV
6. Rated line voltage -----230 VAC, 50/60 Hz, Single phase, 1.4 kVA
7. Line voltage range-----207 VAC - 253 VAC
8. Range of line voltage regulation-----0 - 3 % (Apparent resistance 1.02 ohm)
9. Rated line current -----6 A at 70 kV, 6 mA
10. Maximum line current -----7 A at 70 kV, 6 mA
11. Exposure time -----0.01 - 2.0 sec.
12. Inherent filtration-----1.7 mm Al Equivalent
13. Added filtration -----0.3 mm Al
14. Minimum filtration permanently in useful beam-----2.0 mm Al Equivalent at 70 kV
15. Nominal radiation output -----Refer to Nominal Radiation Output Table on the next page.
16. Nominal electrical output of H.V. generator -----0.42 kW at 70 kV, 6 mA
17. Cone

	Source to skin distance	Field size
a. Regular cone -----	203 mm	58 mm dia., circular
b. Long cone (option) -----	305 mm	58 mm dia., circular
c. Rectangular collimator (option)-----	SSD of cone + 40mm	32 x 40 mm, rectangular
18. Maximum symmetrical radiation field-----60 mm dia. at distal end of cone
19. Leaking technique factor -----70 kV / 0.19 mA (697mAs at 1 hour)
(0.19 mA is maximum rated continuous current for 6mA with a duty cycle 1:30)
20. Duty cycle-----1 : 30 (0.5 sec. exposure with 15 sec. interval)
21. Maximum deviation of tube potential, tube current and exposure time
 - a. Below 0.1 sec. setting ----- ± 10 kV, ± 2 mA, ± 5 msec.
 - b. 0.1 sec. setting & up----- ± 5 kV, ± 1 mA, ± 10 msec.
22. Measurement base of technique factors
 - a. peak tube potential-----Average of peak tube potentials during one exposure
 - b. tube current-----Average of tube current during one exposure
 - c. exposure time-----Time period during x-ray is emitted
23. Half value layer -----1.5 mm Al over
24. Source to the base of cone distance-----94 mm
25. Environmental condition for storage-----20 - 70 °C, 10 - 100 %, 500 - 1060 hPa
26. Environmental condition for operation-----10 - 40 °C, 30 - 70 %, 700 - 1060 hPa
27. Dose area product -----Estimated air kerma displayed [mGy]
x 26.4 [cm²] (for regular and long cone)
Estimated air kerma displayed [mGy]
x 12.8 [cm²] (for rectangular collimator)
28. Service life-----10 years

Nominal Radiation Output Table

Exp. Time [sec.]	Nominal Radiation Output															
	without Rectangular Collimator								with Rectangular Collimator							
	60 kV				70 kV				60 kV				70 kV			
	Regular Cone		Long Cone		Regular Cone		Long Cone		Regular Cone		Long Cone		Regular Cone		Long Cone	
	3mA	6mA	3mA	6mA	3mA	6mA	3mA	6mA	3mA	6mA	3mA	6mA	3mA	6mA	3mA	6mA
0.00	0.00	0.00	0.00	0.00	0.00	0.00	0.00	0.00	0.00	0.00	0.00	0.00	0.00	0.00	0.00	0.00
0.01	0.05	0.09	0.02	0.04	0.06	0.12	0.03	0.05	0.03	0.06	0.02	0.03	0.04	0.08	0.02	0.04
0.02	0.09	0.18	0.04	0.08	0.12	0.24	0.05	0.10	0.06	0.13	0.03	0.06	0.08	0.16	0.04	0.08
0.03	0.14	0.27	0.06	0.12	0.18	0.35	0.08	0.16	0.10	0.19	0.05	0.09	0.12	0.25	0.06	0.12
0.04	0.18	0.37	0.08	0.16	0.24	0.47	0.10	0.21	0.13	0.26	0.06	0.13	0.16	0.33	0.08	0.16
0.05	0.23	0.46	0.10	0.20	0.30	0.59	0.13	0.26	0.16	0.32	0.08	0.16	0.21	0.41	0.10	0.20
0.06	0.27	0.55	0.12	0.24	0.35	0.71	0.16	0.31	0.19	0.38	0.09	0.19	0.25	0.49	0.12	0.24
0.07	0.32	0.64	0.14	0.28	0.41	0.83	0.18	0.37	0.22	0.45	0.11	0.22	0.29	0.58	0.14	0.29
0.08	0.37	0.73	0.16	0.32	0.47	0.94	0.21	0.42	0.26	0.51	0.13	0.25	0.33	0.66	0.16	0.33
0.09	0.41	0.82	0.18	0.36	0.53	1.06	0.24	0.47	0.29	0.57	0.14	0.28	0.37	0.74	0.18	0.37
0.10	0.46	0.91	0.20	0.41	0.59	1.18	0.26	0.52	0.32	0.64	0.16	0.32	0.41	0.82	0.20	0.41
0.11	0.50	1.01	0.22	0.45	0.65	1.30	0.29	0.58	0.35	0.70	0.17	0.35	0.45	0.91	0.22	0.45
0.13	0.59	1.19	0.26	0.53	0.77	1.53	0.34	0.68	0.41	0.83	0.21	0.41	0.54	1.07	0.27	0.53
0.14	0.64	1.28	0.28	0.57	0.83	1.65	0.37	0.73	0.45	0.89	0.22	0.44	0.58	1.15	0.29	0.57
0.16	0.73	1.46	0.32	0.65	0.94	1.89	0.42	0.84	0.51	1.02	0.25	0.51	0.66	1.32	0.33	0.65
0.18	0.82	1.65	0.36	0.73	1.06	2.12	0.47	0.94	0.57	1.15	0.28	0.57	0.74	1.48	0.37	0.73
0.20	0.91	1.83	0.41	0.81	1.18	2.36	0.52	1.05	0.64	1.28	0.32	0.63	0.82	1.65	0.41	0.82
0.22	1.01	2.01	0.45	0.89	1.30	2.60	0.58	1.15	0.70	1.40	0.35	0.70	0.91	1.81	0.45	0.90
0.25	1.14	2.29	0.51	1.01	1.48	2.95	0.65	1.31	0.80	1.60	0.40	0.79	1.03	2.06	0.51	1.02
0.28	1.28	2.56	0.57	1.13	1.65	3.30	0.73	1.46	0.89	1.79	0.44	0.89	1.15	2.31	0.57	1.14
0.32	1.46	2.93	0.65	1.30	1.89	3.78	0.84	1.67	1.02	2.04	0.51	1.01	1.32	2.64	0.65	1.31
0.36	1.65	3.29	0.73	1.46	2.12	4.25	0.94	1.88	1.15	2.30	0.57	1.14	1.48	2.97	0.73	1.47
0.40	1.83	3.66	0.81	1.62	2.36	4.72	1.05	2.09	1.28	2.55	0.63	1.27	1.65	3.29	0.82	1.63
0.45	2.06	4.12	0.91	1.82	2.66	5.31	1.18	2.35	1.44	2.87	0.71	1.42	1.85	3.71	0.92	1.84
0.50	2.29	4.57	1.01	2.03	2.95	5.90	1.31	2.61	1.60	3.19	0.79	1.58	2.06	4.12	1.02	2.04
0.56	2.56	5.12	1.13	2.27	3.30	6.61	1.46	2.93	1.79	3.57	0.89	1.77	2.31	4.61	1.14	2.29
0.63	2.88	5.76	1.28	2.55	3.72	7.43	1.65	3.29	2.01	4.02	1.00	1.99	2.59	5.19	1.29	2.57
0.71	3.25	6.49	1.44	2.88	4.19	8.38	1.86	3.71	2.27	4.53	1.12	2.25	2.92	5.85	1.45	2.90
0.80	3.66	7.32	1.62	3.24	4.72	9.44	2.09	4.18	2.55	5.11	1.27	2.53	3.29	6.59	1.63	3.27
0.90	4.12	8.23	1.82	3.65	5.31	10.6	2.35	4.70	2.87	5.74	1.42	2.85	3.71	7.4	1.84	3.67
1.00	4.57	9.15	2.03	4.05	5.90	11.8	2.61	5.23	3.19	6.38	1.58	3.16	4.12	8.2	2.04	4.08
1.12	5.12	10.2	2.27	4.54	6.61	13.2	2.93	5.85	3.57	7.1	1.77	3.54	4.61	9.2	2.29	4.57
1.25	5.72	11.4	2.53	5.06	7.38	14.8	3.27	6.53	3.99	8.0	1.98	3.96	5.15	10.3	2.55	5.10
1.40	6.40	12.8	2.84	5.67	8.26	16.5	3.66	7.32	4.47	8.9	2.21	4.43	5.77	11.5	2.86	5.72
1.60	7.32	14.6	3.24	6.48	9.44	18.9	4.18	8.36	5.11	10.2	2.53	5.06	6.59	13.2	3.27	6.53
1.80	8.23	16.5	3.65	7.29	10.6	21.2	4.70	9.41	5.74	11.5	2.85	5.70	7.41	14.8	3.67	7.35
2.00	9.15	18.3	4.05	8.10	11.8	23.6	5.23	10.5	6.38	12.8	3.16	6.33	8.24	16.5	4.08	8.17

unit: [mGy] $\pm 50\%$

[13] PHYSICAL DIMENSIONS

[unit : mm]

1. Wall mount type (WK)

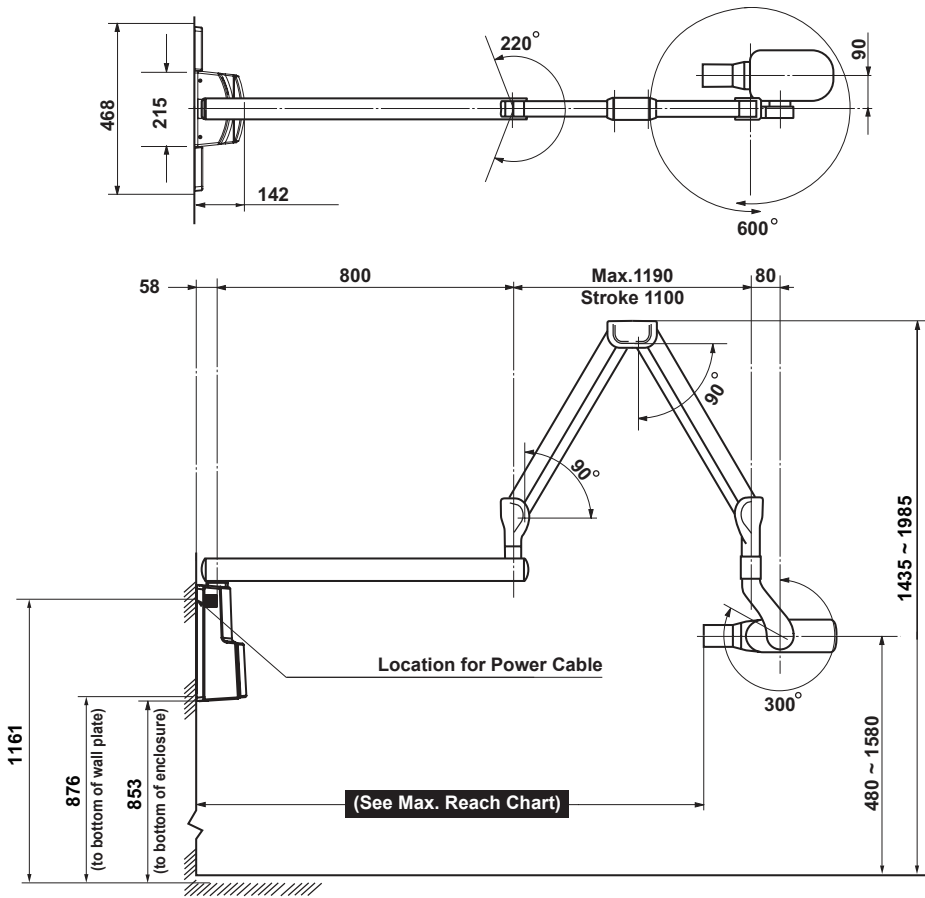

Maximum Reach	
2122 mm	with 1000 mm arm
1922 mm	with 800 mm arm
1622 mm	with 500 mm arm
1422 mm	with 300 mm arm

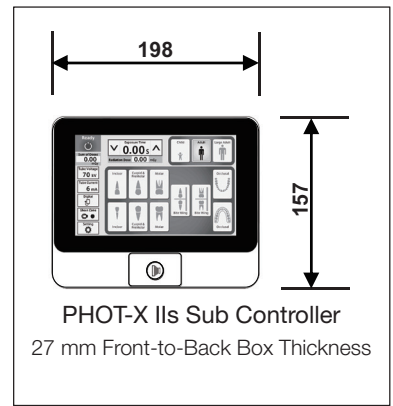

2. Floor mount type (FK)

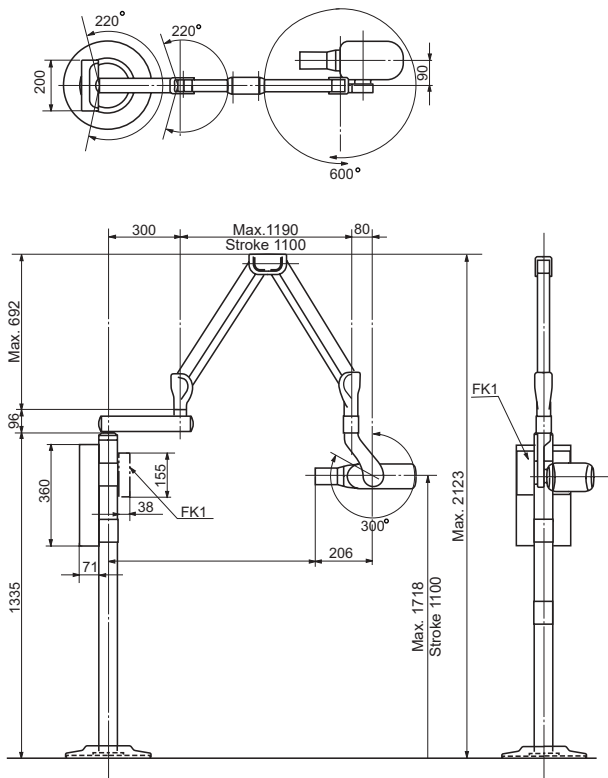

3. Floor mobile type (FM)

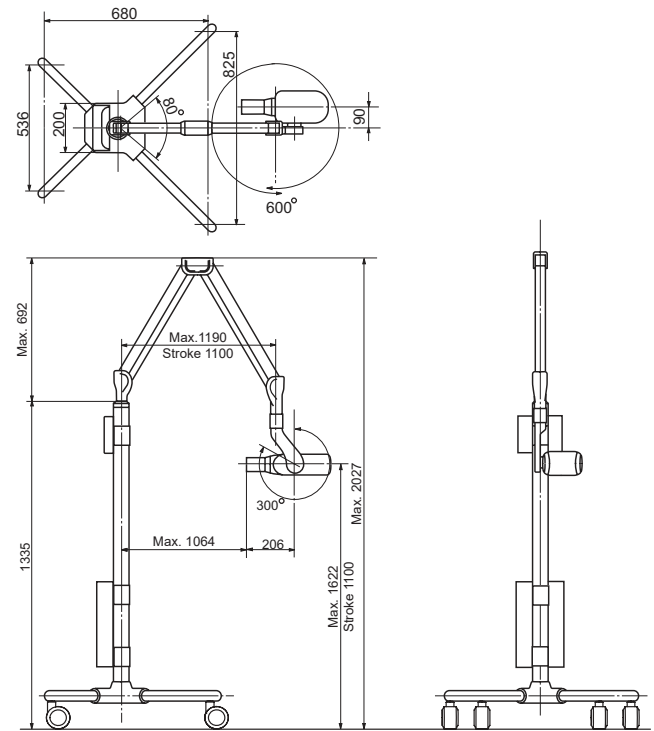

4. Ceiling mount type (CK)

except for Germany

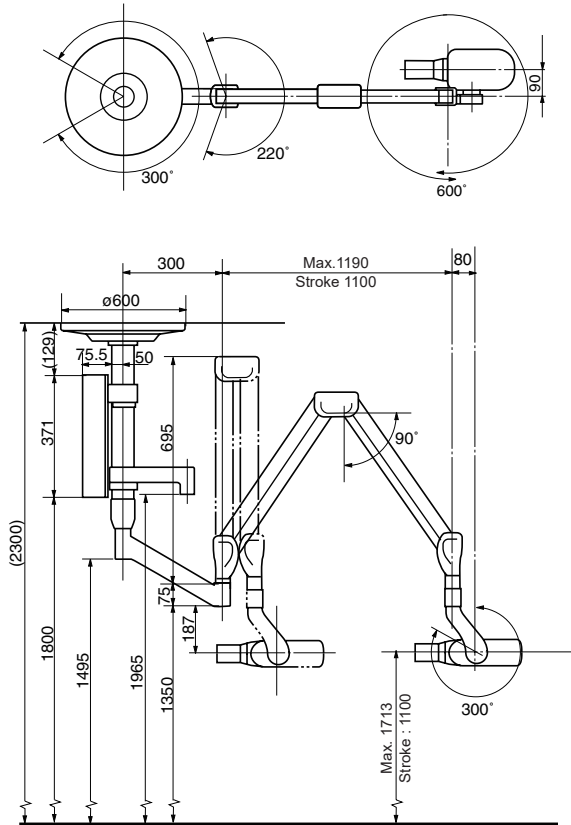

for Germany

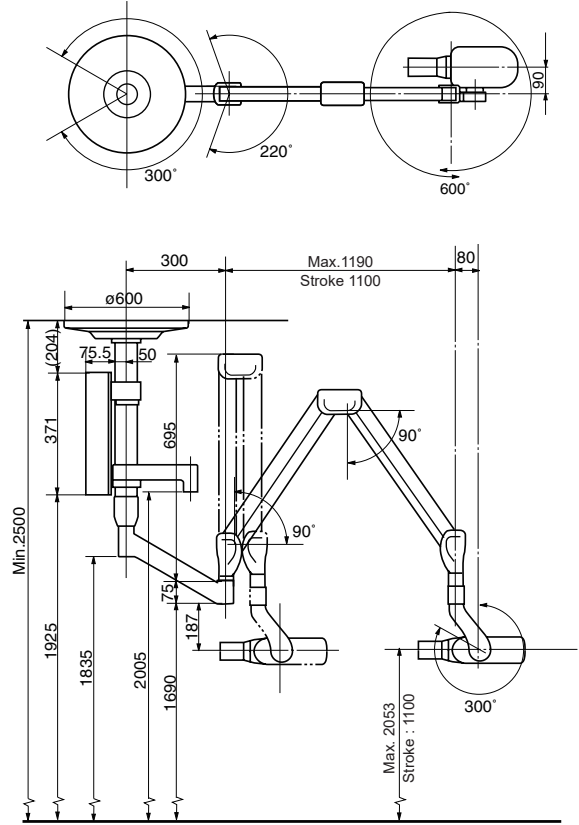

5. Room mount type (RK)

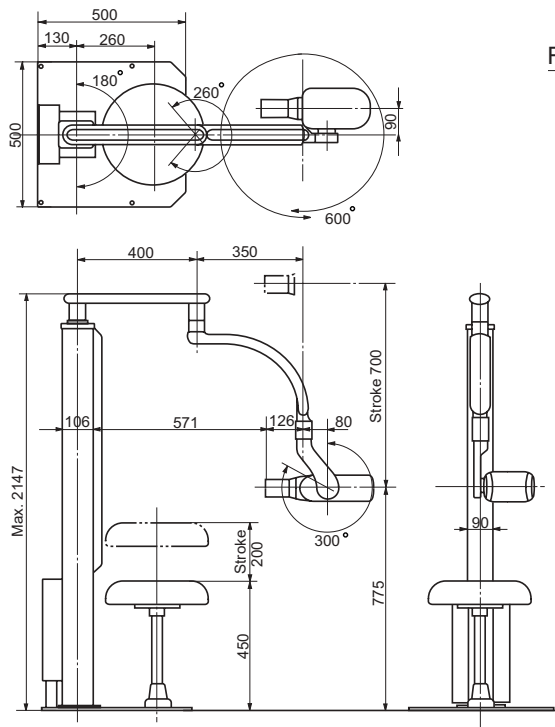

Focal Spot Marking

Reference Axis

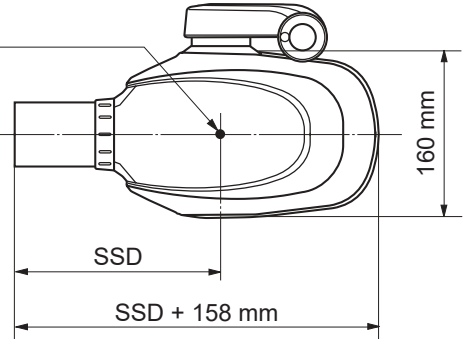

SSD (Source to Skin Distance) :

- a. Regular cone ----- 203 mm
- b. Long cone ----- 305 mm

Note: Installation of rectangular collimator increases SSD by 40 mm from above value.

[14] ELECTROMAGNETIC COMPATIBILITY (EMC)

This product conforms to EMC standard EN60601-1-2:2015.

1. Caution to EMC and Compliance with information in attached document

Medical electrical equipment requires special attention to EMC and it must be installed and used according to the EMC information provided in this instruction manual. Do not install in the vicinity of the electrosurgical device being output or electromagnetically shielded room of ME system for MRI diagnostic imaging because the electromagnetic interference intensity is high.

WARNING

- a. Use of this equipment adjacent to or stocked with other equipment should be avoided because it should result in improper operation. If such use is necessary, this equipment and the other equipment should be observed to verify that they are operating normally.
- b. Use of accessories, transducers and cables other than those specified or provided by the manufacturer of this equipment could result in increased electromagnetic emissions or decreased electromagnetic immunity of this equipment and result in improper operation.
- c. Portable RF communications equipment (including peripherals such as antenna cables and external antennas) should be used no closer than 30cm (12 inches) to any part of the PHOT-X IIs 505, including cables specified by the manufacturer. Otherwise, degradation of the performance of this equipment could result.

2. Electromagnetic emissions

Emissions test	Test procedure	Compliance	Note : The emissions characteristics of this equipment make it suitable for use in industrial areas and hospitals (CISPR 11 class A). If it is used in a residential environment (for which CISPR 11 class B is normally required) this equipment might not offer adequate protection to radio-frequency communication services. The user might need to take mitigation measures, such as relocating or reorienting the equipment.
Conducted and radiated RF emissions	CISPR11	Group 1 Class A	
Harmonic distortion	EN61000-3-2	N/A ^(*1)	
Voltage fluctuations and flicker	EN61000-3-3	Clause 5	

(*1) : The test is not applicable since professional equipment is rated power 1kW or more.

3. Electromagnetic immunity

Immunity test	EN 60601 test level	Compliance level	Electromagnetic environment - guidance
Electrostatic discharge (ESD) EN61000-4-2	±8 kV contact ±15 kV air	±8 kV contact ±15 kV air	Floors should be wood, concrete or ceramic tile. If floors are covered with synthetic material, the relative humidity should be at least 30%.
Electrical fast transient/burst EN61000-4-4	±2 kV for power supply lines ±1 kV for input/output lines	±2 kV for power supply lines ±1 kV for input/output lines	Mains power quality should be that of a typical commercial or hospital environment.
Surge EN61000-4-5	±1 kV differential mode ±2 kV common mode	±1 kV differential mode ±2 kV common mode	Mains power quality should be that of a typical commercial or hospital environment.

Immunity test	EN 60601 test level	Compliance level	Electromagnetic environment - guidance
Voltage dips, short interruptions and voltage variations on power supply input lines EN61000-4-11	<u>dips</u> 0 %Ut: 0.5 cycle (0, 45, 90, 135, 180, 225, 270 and 315 degree) 0 %Ut: 1 cycle (0 degree) 70 %Ut: 25/30 cycles (0 degree) <u>short interruptions</u> 0 %Ut: 250/300 cycles Ut: Rated voltage of EUT	<u>dips</u> 0 %Ut: 0.5 cycle (0, 45, 90, 135, 180, 225, 270 and 315 degree) 0 %Ut: 1 cycle (0 degree) 70 %Ut: 25/30 cycles (0 degree) <u>short interruptions</u> 0 %Ut: 250/300 cycles Ut: Rated voltage of EUT	Mains power quality should be that of a typical commercial or hospital environment. If the user of the PHOT-X IIs 505 x-ray requires continued operation during power mains interruptions, it is recommended that the PHOT-X IIs 505 x-ray be powered from an uninterruptible power supply or a battery.!
Power frequency (50/60Hz) magnetic field EN61000-4-8	30 A/m	30 A/m	Power frequency magnetic fields should be at levels characteristic of a typical location in a typical commercial or hospital environment.
Conducted RF EN61000-4-6	AC/DC power and Signal input/output 0.15 MHz - 80 MHz: 3V 6 V in ISM bands between 0.15 MHz - 80MHz (unmodulated, r.m.s.) 80 % AM (1 kHz)	AC/DC power and Signal input/output 0.15 MHz - 80 MHz: 3V 6 V in ISM bands between 0.15 MHz - 80MHz (unmodulated, r.m.s.) 80 % AM (1 kHz)	Portable RF communications equipment (including peripherals such as antenna cables and external antennas) should be used no closer than 30cm (12 inches) to any part of the PHOT-X IIs 505, including cables specified by the manufacturer. Otherwise, degradation of the performance of this equipment could result.
Radiated RF EN61000-4-3	80 MHz - 2700 MHz: 3V/m (unmodulated, r.m.s.) 80 % AM (1kHz)	80 MHz - 2700 MHz: 3V/m (unmodulated, r.m.s.) 80 % AM (1kHz)	
Proximity fields from RF wireless communication equipment EN61000-4-3	385 MHz 27 V/m (unmodulated, r.m.s.) Pulse modulation 18 Hz	385 MHz 27 V/m (unmodulated, r.m.s.) Pulse modulation 18 Hz	
	450 MHz 28 V/m (unmodulated, r.m.s.) FM ± 5 kHz deviation 1 kHz sine or Pulse modulation 18 Hz	450 MHz 28 V/m (unmodulated, r.m.s.) FM ± 5 kHz deviation 1 kHz sine or Pulse modulation 18 Hz	
	710 MHz, 745 MHz, 780 MHz 9 V/m (unmodulated, r.m.s.) Pulse modulation 217 Hz	710 MHz, 745 MHz, 780 MHz 9 V/m (unmodulated, r.m.s.) Pulse modulation 217 Hz	
	810 MHz, 870 MHz, 930 MHz 28 V/m (unmodulated, r.m.s.) Pulse modulation 18 Hz	810 MHz, 870 MHz, 930 MHz 28 V/m (unmodulated, r.m.s.) Pulse modulation 18 Hz	
	1720 MHz, 1845 MHz, 1970 MHz 28 V/m (unmodulated, r.m.s.) Pulse modulation 217 Hz	1720 MHz, 1845 MHz, 1970 MHz 28 V/m (unmodulated, r.m.s.) Pulse modulation 217 Hz	
	2450 MHz 28 V/m (unmodulated, r.m.s.) Pulse modulation 217 Hz	2450 MHz 28 V/m (unmodulated, r.m.s.) Pulse modulation 217 Hz	
	5240 MHz, 5500 MHz, 5785 MHz 9 V/m (unmodulated, r.m.s.)	5240 MHz, 5500 MHz, 5785 MHz 9 V/m (unmodulated, r.m.s.)	

4. Essential performance

Unless the exposure switch is pressed, x-ray is not exposed.

If the Essential performance is lost or deteriorated, the device may operate inadvertently and may harm the patient, the operator, and the surrounding people.

[15] OTHER INFORMATION

1. The nature of the emitted radiation;

It is ionizing radiation for diagnostic purposes. Diagnosis is made by obtaining the absorption pattern of this radiation passing through the teeth, jaws, and structures of the oral cavity.

2. The type of the emitted radiation; X-ray

3. Ways of avoiding misuse and of appropriately reducing the risks inherent to transport, storage, and installation;

The pictograms are employed to make the appropriate dose for each tooth and patient size rather than having the operator manually set the exposure time. For transportation and storage, the environment is specified on the outer packaging and in the manual. After installation, the installer is instructed to verify that the device functions correctly.

4. The intensity of the emitted radiation;

Refer to the table on page 18 for the rated dose at the distal end of the cone.

5. The distribution of the emitted radiation;

The radiation area is the infinite conical space (when a round cone is used) or the quadrangular pyramidal space (when a rectangular cone is used) obtained by connecting the boundary of the radiation field at the cone tip and the focal point. The radiation dose is inversely proportional to the square of the distance from the focal point.

6. The recommended dose of emitted radiation;

The dose should be varied depending on the sensitivity of the x-ray receiver used, the teeth to be imaged, and the patient's size. For example, in the case of the Kodak InSight film, the speed setting of F.05 is recommended, and the exposure conditions for each tooth and patient size are shown in the table on page 8. The dose when irradiated under the conditions in this table is shown in the rated dose table on page 18.

7. Means of protecting the patients, the user, or a third party from unintended radiation during the use of medical devices;

See [1] 6.b. on page 1.

[16] DISPOSAL

1. Disposal of x-ray unit or components

The tube head of this x-ray unit contains the lead for x-ray shield and oil, which is refined mineral oil and does not contain the carcinogenic substances such as PCBs, for the insulation.

When disposing the x-ray unit or components, appropriately dispose them complying with all current applicable regulations and local codes. In EU area, EU directive 2012/19/EU on waste electrical and electronic equipment (WEEE) is applied on this product. In this directive, environment conscious recycling / abandonment is obligated.

2. Disposal of used film covers and CCD covers

Dispose the used film covers and CCD sensor covers appropriately, according to procedures indicated by each manufacturer and all current applicable regulations and local codes.

[17] LABEL LOCATION

X-RAY CONTROLLER(MAIN)
PHOT-XiIS 505 (WK) Type
 TYPE DENTAL X-RAY COMP 505-CM
 REF AR-55WK5EU
 SN EX21E0001
 INPUT 230V ~ 50/60Hz 1.4kVA
 OUTPUT 60/70kV 3/6mA
 2sec
 1:30 12sec

 Takara Belmont Corp.
 2-1-1 Higashi-hinabashi, Chuo-ku, Osaka, Japan
 EC REP TAKARA COMPANY EUROPE GmbH
 Berner Strasse 18, 60437 Frankfurt am Main, Germany

(WK Type)

X-RAY CONTROLLER(MAIN)
PHOT-XiIS 505 (RK) Type
 TYPE DENTAL X-RAY COMP 505-CMRK
 REF AR-55RK5EU
 SN EX21E0001
 INPUT 230V ~ 50/60Hz 1.4kVA
 OUTPUT 60/70kV 3/6mA
 2sec
 1:30 12sec

 Takara Belmont Corp.
 2-1-1 Higashi-hinabashi, Chuo-ku, Osaka, Japan
 EC REP TAKARA COMPANY EUROPE GmbH
 Berner Strasse 18, 60437 Frankfurt am Main, Germany

(RK Type)

X-RAY CONTROLLER(MAIN)
PHOT-XiIS 505 (FM) Type
 TYPE DENTAL X-RAY COMP 505-CMFM
 REF AR-55FM5EU
 SN EX21E0001
 INPUT 230V ~ 50/60Hz 1.4kVA
 OUTPUT 60/70kV 3/6mA
 2sec
 1:30 12sec
 Weight of whole unit 67kg

 Takara Belmont Corp.
 2-1-1 Higashi-hinabashi, Chuo-ku, Osaka, Japan
 EC REP TAKARA COMPANY EUROPE GmbH
 Berner Strasse 18, 60437 Frankfurt am Main, Germany

(FM Type)

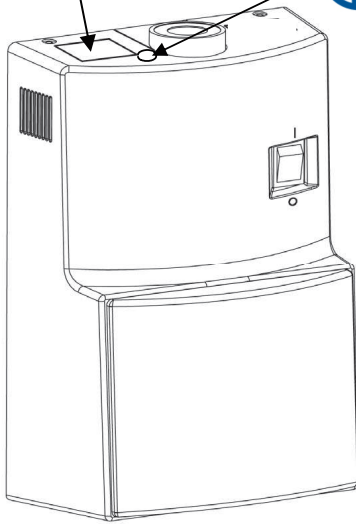

X-RAY CONTROLLER(MAIN)
PHOT-XiIS 505 (FK) Type
 TYPE DENTAL X-RAY COMP 505-CMFK
 REF AR-55FK5EU
 SN EX21E0001
 INPUT 230V ~ 50/60Hz 1.4kVA
 OUTPUT 60/70kV 3/6mA
 2sec
 1:30 12sec

 Takara Belmont Corp.
 2-1-1 Higashi-hinabashi, Chuo-ku, Osaka, Japan
 EC REP TAKARA COMPANY EUROPE GmbH
 Berner Strasse 18, 60437 Frankfurt am Main, Germany

(Type FK)

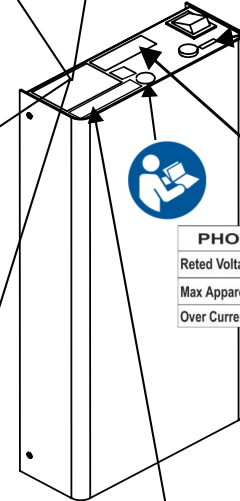

F6.3AH, 250V

(FM, FK, RK Type)

PHOT-XiIS		Power supply requirements					
Rated Voltage	[Vac]	100	110	120	220	230	240
Max Apparent Resistance	[Ω]	0.39	0.45	0.52	0.91	0.98	1.06
Over Current Release	[A]	≥ 15		≥ 10			

(FM, FK, RK Type)

X-RAY CONTROLLER(MAIN)
PHOT-XiIS 505 (CK) Type
 TYPE DENTAL X-RAY COMP 505-CMCK
 REF AR-55CK5EU
 SN EX21E0001
 INPUT 230V ~ 50/60Hz 1.4kVA
 OUTPUT 60/70kV 3/6mA
 2sec
 1:30 12sec

 Takara Belmont Corp.
 2-1-1 Higashi-hinabashi, Chuo-ku, Osaka, Japan
 EC REP TAKARA COMPANY EUROPE GmbH
 Berner Strasse 18, 60437 Frankfurt am Main, Germany

(CK Type)

CAUTION ATTENTION DO NOT MOVE ENTIRE X-RAY UNIT WITH ARM EXTENDED
 NE PAS DEPLACER L'APPAREIL COMPLET AVEC SON BRAS ETENDU.

(FM Type)

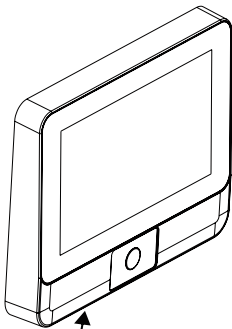

X-RAY LONG CONE
 TYPE DENTAL X-RAY COMP 505-L
 SN ED21E0001
 SSD 305mm BEAM LIMITING DEVICE
 EXIT FIELD SIZE 58mm dia., circular

 Takara Belmont Corp.
 2-1-1 Higashi-hinabashi, Chuo-ku, Osaka, Japan
 EC REP TAKARA COMPANY EUROPE GmbH
 Berner Strasse 18, 60437 Frankfurt am Main, Germany

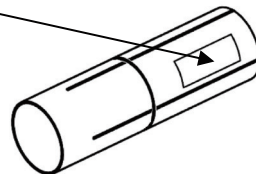

X-RAY CONTROLLER(SUB)
 TYPE DENTAL X-RAY COMP 505-CSL
 SN EC21E0001

 Takara Belmont Corp.
 2-1-1 Higashi-hinabashi, Chuo-ku, Osaka, Japan
 EC REP TAKARA COMPANY EUROPE GmbH
 Berner Strasse 18, 60437 Frankfurt am Main, Germany

X-RAY HEAD
 TYPE DENTAL X-RAY COMP 505-H
 SN EH21E0001
 OUTPUT 60/70kV 3/6mA
 TUBE D-046 1234567 CANON

 Takara Belmont Corp.
 2-1-1 Higashi-hinabashi, Chuo-ku, Osaka, Japan
 EC REP TAKARA COMPANY EUROPE GmbH
 Berner Strasse 18, 60437 Frankfurt am Main, Germany

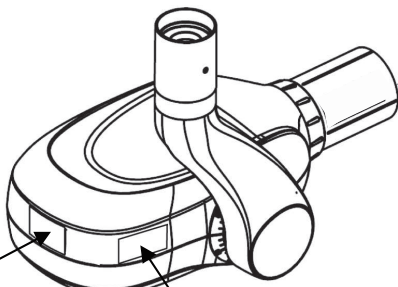

X-RAY RECTANGULAR COLLIMATOR
 TYPE DENTAL X-RAY COMP 505-REC
 SN EE21E0001
 SSD 243mm (with regular cone), 345 (with long cone)
 EXIT FIELD SIZE 32 x 40mm, rectangular

 Takara Belmont Corp.
 2-1-1 Higashi-hinabashi, Chuo-ku, Osaka, Japan
 EC REP TAKARA COMPANY EUROPE GmbH
 Berner Strasse 18, 60437 Frankfurt am Main, Germany

X-RAY REGULAR CONE
 TYPE DENTAL X-RAY COMP 505-R
 SN ER21E0001
 SSD 203 mm
 EXIT FIELD SIZE 58mm dia., circular

 Takara Belmont Corp.
 2-1-1 Higashi-hinabashi, Chuo-ku, Osaka, Japan
 EC REP TAKARA COMPANY EUROPE GmbH
 Berner Strasse 18, 60437 Frankfurt am Main, Germany

FOCAL SPOT VALUE	: 0.4
INHERENT FILTRATION	: 1.7 mmAl Equiv
ADDED FILTRATION	: 0.3 mmAl
TOTAL FILTRATION	: 2.0 mmAl Equiv
RADIATION LEAKAGE RATE	: 108 μGy/H at 1m

X-RAY ARM

TYPE	DENTAL X-RAY	COMP	505-A
SN	EA21E0001	MV JP	2021-05

Belmont
Takara Belmont Corp.
2-1-1 Higashishinbashi, Chuo-ku, Osaka, Japan

EC REP TAKARA COMPANY EUROPE GmbH
Bernner Strasse 18, 60437 Frankfurt am Main, Germany

(WK, FM, FK and CK Type)

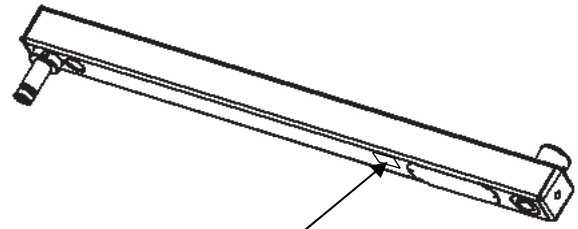
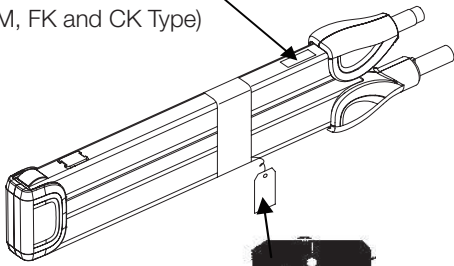

X-RAY HORIZONTAL ARM

TYPE	DENTAL X-RAY	COMP	505-HA
SN	EG21E0001	MV JP	2021-05

Belmont
Takara Belmont Corp.
2-1-1 Higashishinbashi, Chuo-ku, Osaka, Japan

EC REP TAKARA COMPANY EUROPE GmbH
Bernner Strasse 18, 60437 Frankfurt am Main, Germany

(WK and FK Type)

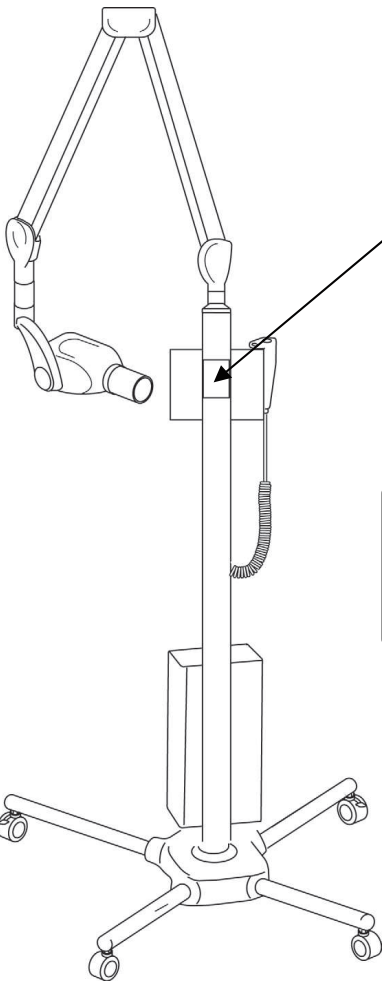

(FM Type)

WARNING
Keep casters in the lock position, unless moving the equipment. To avoid injury, do not push or lean on the equipment.

AVERTISSEMENT
Gardez les roulettes en position verrouillée à moins que vous ayez à déplacer l'appareil. Il y a risque de blessure si vous appuyez ou poussez sur l'appareil.

X-RAY ROOM MOUNT

TYPE	DENTAL X-RAY	COMP	505-RK
SN	EB21E0001	MV JP	2021-05

Belmont
Takara Belmont Corp.
2-1-1 Higashishinbashi, Chuo-ku, Osaka, Japan

EC REP TAKARA COMPANY EUROPE GmbH
Bernner Strasse 18, 60437 Frankfurt am Main, Germany

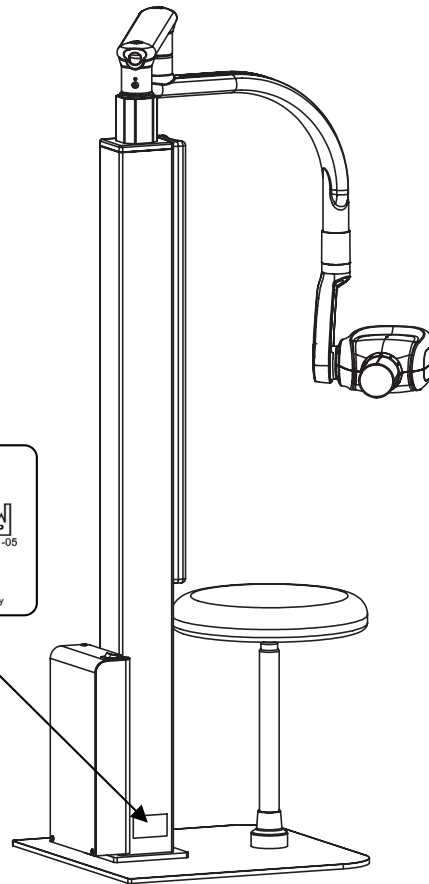

(RK Type)

NOTE

EC REP

TAKARA COMPANY EUROPE GmbH
Berner Strasse 18, 60437
Frankfurt am Main, Germany
Tel:+49 69 506878 0
Fax:+49 69 506878 20

 **Belmont**[®]

 **TAKARA BELMONT CORPORATION**
2-1-1, Higashishinsaibashi, Chuo-ku, Osaka, 542-0083, Japan
TEL: +81 6 6213 5945
TELEFAX: +81 6 6212 3680

BOOK NO. 1A0SBWE0

2024-02